

TANK SPECS

TANK SIZE
 _____ DIAMETER
 _____ SIDE SHELL HEIGHT
 _____ OVER ALL HEIGHT IF REQ'D

WORKING PRESSURE

_____ 100 PSI
 _____ 125 PSI
 _____ 150 PSI
 _____ OTHER _____ PSI

CODE REQUIREMENTS

_____ NON CODE
 _____ CODE

TANK LINING (INTERIOR)

_____ STANDARD EPOXY
 _____ SPECIAL EPOXY _____ MILS
 _____ GALVANIZED
 _____ OTHER _____

TANK COATING (EXTERIOR)

_____ GALVANIZED
 _____ STANDARD PRIME COAT
 _____ OTHER _____

TANK LEGS

_____ ANGLE LEGS
 _____ STRAP LEGS
 _____ BEAM LEGS
 _____ JACK PADS
 _____ PIPE LEGS
 _____ RING BASE

CHECK IF
 STAINLESS
 LEGS ARE
 REQUIRED

MOUNTING CLIPS

_____ INTERIOR - # C.S. _____ S.S. _____
 _____ EXTERIOR - # C.S. _____ S.S. _____

SPECIAL REQUIREMENTS

_____ LIFT LUGS
 _____ FALSE BOTTOM
 _____ DISTRIBUTOR PLATE
 _____ NUMBER OF HOLES
 _____ SIZE OF HOLES THREADED
 _____ HIGH TEMP _____ °F
 _____ STAINLESS TANK - TYPE _____ S.S.

HEAD SHAPE

_____ STANDARD F & D (STK NON CODE)
 _____ CODE SHAPE F & D (STK NON CODE)
 _____ HIGH CROWN (NOT STOCKED)
 _____ SEMI-ELLIP (STOCK CODE)

FULL COUPLING (FC)

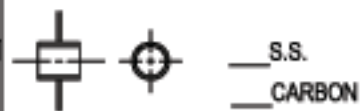

HALF COUPLING (HC)

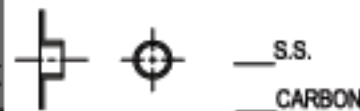

BLIND FLANGE (BF)



SINGLE DRILLED PAD FLANGE (SDPF)



DOUBLE DRILLED PAD FLANGE (DDPF)



FULL SPOOL (FS)

S.S. _____; CARBON _____; FLAT FACE _____; RAISED FACE _____

HALF SPOOL (HS)

S.S. _____; CARBON _____; FLAT FACE _____; RAISED FACE _____

COMPLETE FORM AND FAX TO (250) 595-7306

COMPANY: _____

CONTACT: _____

PHONE: _____

FAX: _____

QUANTITY: _____

LEFT HAND RIGHT HAND

SIGHT WINDOW (SW)

3" X 12" _____ S.S.
 4" X 18" _____ CARBON

HANDHOLE

4" X 6" _____ S.S.
 6" X 8" _____ CARBON

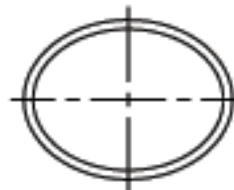

MANHOLE

11" X 15"
 12" X 16"
 14" X 18"
 18" X 24"

_____ S.S.

_____ CARBON

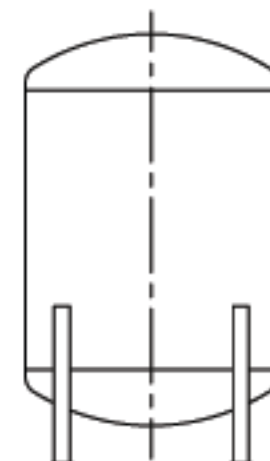
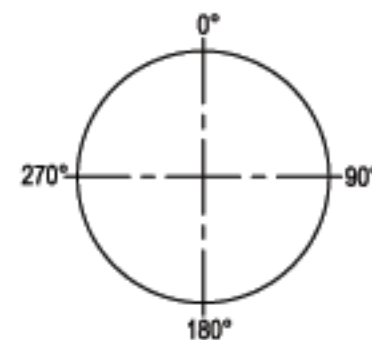

PACKAGING: _____ EACH
 WEIGHT: _____ LBS/EACH
 CAN SHIP IN: _____ WEEKS AFTER DWG APPROVAL

SCHEDULE OF OPENINGS

| MARK | SIZE | TYPE | SERVICE |
|------|------|------|---------|
| A | | | |
| B | | | |
| C | | | |
| D | | | |
| E | | | |
| F | | | |
| G | | | |
| H | | | |

WEST COAST FILTERS INC.

DESIGN, MANUFACTURE, & DISTRIBUTION OF WATER PURIFICATION EQUIPMENT

Hillside P.O. Box 35008

Victoria, BC Canada

V8T 5G2

www.westcoastfilters.com

Toll Free: 1-800-375-7744

Ph: (250) 595-7370

Fax: (250) 595-7306

E-mail: richard@westcoastfilters.com